



International  
Handball  
Federation

# **IX. Rules of the Game**

## **c) Wheelchair Handball**

### **Six-a-Side**

---

*Edition: 19 February 2021*



# Table of contents

Foreword	2
Article 1 – Basics	2
Article 2 – Wheelchair Specifications	5
Article 3 – The Game	6

**Note:** For the sake of simplicity, this rule book generally uses the male form of words with respect to players, officials, referees, and other persons.



## Foreword

The IHF Rules of the Game for Wheelchair Handball Six-a-Side basically follow the IHF Rules of the Game for Indoor Handball.

No special rules shall apply despite having mixed teams. However, due to the different capabilities of players, the amendments listed below shall be implemented and will be used for the upcoming IHF Wheelchair Handball events.



## Article 1

### 1. Basics

#### 1.1. The Game

Wheelchair handball six-a-side is played by two teams of six players including one goalkeeper per team. The aim of each team is to score goals and to prevent the other team from scoring.

Wheelchair handball shall be based on the spirit of Fair Play, dedicated for players with physical impairments.

#### 1.2. The Team

A team delegation consists of a maximum of 20 persons including a minimum of 12 players and a maximum of 16 players. A minimum of three female players shall be part of the team. During a match six players including minimum one female player have to be on the court.

#### 1.3. Players

Players have to verify their status during the classification evaluation. All officials have to be aware of the status of the players. For details please refer to the Classification Manual.

Players shall be min. 15 years old; a written permission from the parents for players aged 15-18 years shall be presented prior to the tournament.

#### 1.4. Playing Time

Matches will be played with two halves of 20 minutes each. The half-time break will be 10 minutes.

Each team shall be granted one 1-minute team time-out in each half of the regular playing time. The team requesting a team time-out must be in the possession of the ball.

## 1.5. The Ball

The tournament will be played with size 2 balls following the official IHF dimensions.

## 1.6. The Court

The entire surface of the court should be at least 44 m long and 25 m wide. The playing court is a 40 metres long and 20 metres wide rectangle, consisting of two goal areas and a playing area. The longer boundary lines are called side lines, and the shorter ones are called goal lines (between the goalposts) or outer goal lines (on either side of the goal).

The substitution area should be 4.5 m long. There should be a safety zone surrounding the playing court, with a width of 2 m behind the goal lines. The safety zone along the side lines should be 4 m wide on the side of the substitution area and 1 m on the opposite side.

A max. of four chairs shall be available on every side for the team officials.

### Diagram 1: The playing court

Dimensions indicated in cm.

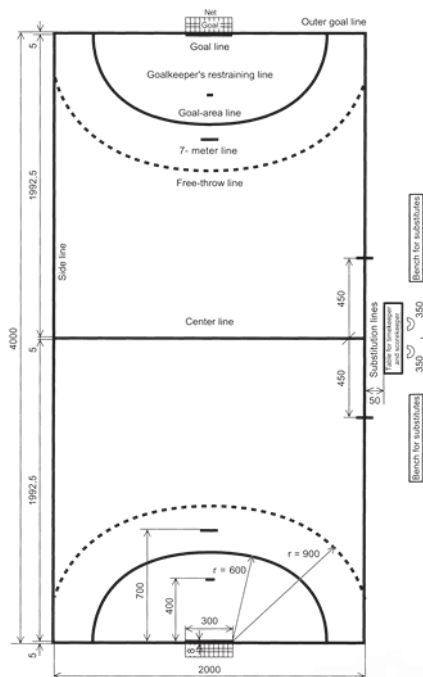

## Diagram 2: Substitution lines and substitution area

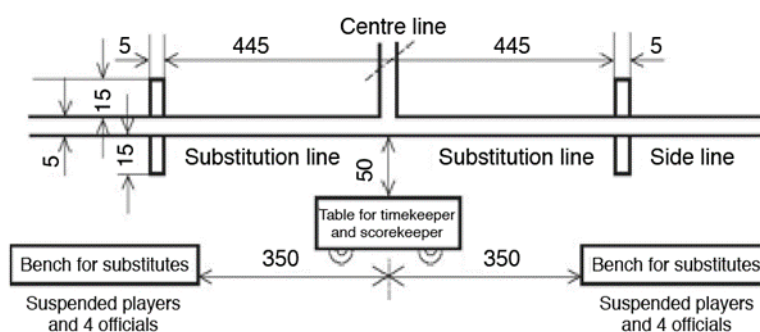

### 1.7. Goal

Goals shall be 3 m x 1.7 m. The catch net in the goals shall be removed (or fixed to the goal net) in order to avoid entangling with the wheelchair.



### 1.8. Equipment

The following material is not permitted:

- Glue for handling the ball
- Protective equipment if including metal components
- Prostheses
- Finger, hand, wrist, etc. braces made of plastic, metal, etc.

It is permitted to use:

- Gloves (soft, without any support, etc.)
- Protective equipment if padded / soft (not including metal)
- Taping band for fingers, arms, etc.

However all equipment shall be presented on the occasion of the technical meeting for a final decision. The IHF Regulations on Protective Equipment and Accessories shall be applied.

## 1.9. Playing Kit

Each team shall arrive with 2 playing kits (one light colour / one dark colour). The jerseys shall have the player's number on the front (10 cm in height).

Special protective equipment customized to the players does not need to have the same colour as the dresses.

A colour code will be used to identify the class of each player. The code (=sticker) including the player's number will be placed on the back rest of the wheelchair after the classification.

Class 1 = green	Class 3 = blue
Class 2 = yellow	Class 4 = red

## 1.10. Straps

Players have to be strapped to the wheelchair at the upper and lower legs in order to avoid lifting or moving/using the legs.

Lifting of field players when playing / defending the ball will be punished with a 2-minute suspension; lifting of the goalkeeper while defending will be punished with a 2-minute suspension and the awarding of a 7m throw.



# Article 2

## 2. Wheelchair Specifications

The wheelchairs shall be constructed in a safe and fair way without any risk for the player himself, his team colleagues or the opposing team. A wheelchair may be banned from the game if there is any concern about its safety or fairness (IHF Officials' decision). All wheelchairs used in the tournament will be checked by the officials prior to the tournament. Only verified wheelchairs can be used during the tournament.

Each team is solely responsible for maintenance, etc. of their wheelchairs during the tournament.

The following specifications shall apply:

- No electronic wheelchairs are allowed.
- A horizontal bar shall be placed at the front of the wheelchair (at a height of approx. 11 cm above floor level). However, it is mandatory to use a complete wing covering the front and side of the wheelchair in order to protect the players.
- 1 – 2 anti-tip devices shall be attached to the wheelchair.
- The maximum height (from the floor to the top of the cushion or seat platform) shall not exceed 63 cm.

- 5 – 6 wheels (2 large wheels in the rear, two at the front and one or two safety wheels on the back. Max. diameter of large wheels: 71 cm (28 inches).
- 1 hand rim on each wheel obligatory.
- Both wheels need to be fully covered. When using cover all players of one team shall use the same design.
- In case carbon fibre spokes are used, no cover will be needed.
- Padding of bar at back of the backrest (15 mm).
- If a wheelchair is no longer functional or unsafe the player has to leave the field for any repairs.

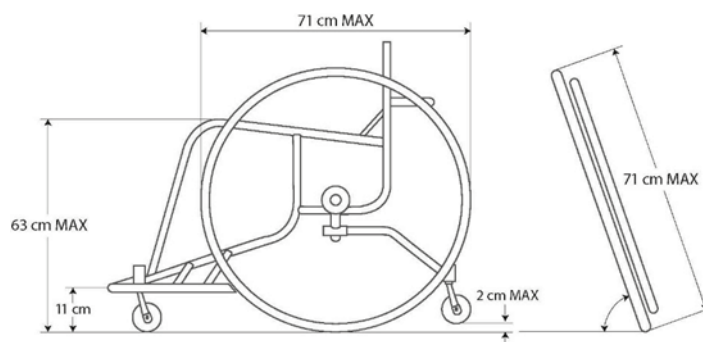

## Article 3

### 3. The Game

#### 3.1. Playing the Ball

It is permitted to:

- throw, catch, stop, push or hit the ball by using hands, arms, head and torso;
- hold the ball for a maximum of 3 seconds;
- push the wheelchair and dribble the ball;
- place the ball on the lap (not between the knees) while pushing the wheelchair for a maximum of 3 seconds;
- monitor and follow the opponent (with or without ball) by using arms and hands as long as the opponent has enough time and distance to react and no danger is present;
- block or force away an opponent with arms or hands, wheelchair (when player is not in great speed);
- enter the goal area or cross the side lines without the ball after a shot or after being pushed when not creating an advantage doing so; the player has to leave the goal area as soon and fast as possible.

It is not permitted to:

- touch the ball more than once, after it has been controlled, unless it has touched the floor, another player, or the goal in the meantime; however, touching it more than once is not penalised, if the player is “fumbling” the ball, i.e., failing to control it when trying to catch or stop it;
- start bouncing (by the same player) after a throw, before another player or a goalpost touched the ball;
- stop the ball with the wheelchair outside the goal area;
- enter the goal area with the ball under control (as court player);
- cross the side line with the ball under control (the wheelchair has to be IN the field).

**Remarks:**

*The wheelchair can be pushed for a maximum of 3 seconds; it is allowed to place the ball on the lap during these pushes. A ball on the lap is considered as “under control”. The opponent is therefore not allowed to take the ball off the laps.*

*After receiving the ball, the player has to start the action by bouncing.*

*“Pushing” means pushing/moving the wheel. When the hand leaves the wheel the next action (dribbling, passing, shooting) has to follow within 3 seconds. It is not allowed to touch the wheel again after those 3 seconds.*

*It is not allowed to hold the ball for more than 3 seconds.*

*In case a ball is thrown against a wheelchair or covered under a wheelchair the referees have to decide on the intention and the respective consequences.*

*It is allowed to use/touch the wheelchair for picking up the ball.*

*The new rules regarding goalkeeper, 30 seconds and passive play shall apply.*

### **3.2. Violations**

Violations shall be handled according to the IHF Rules of the Game for Indoor Handball:

- Yellow card
- 2-minute suspension
- Disqualification
- Team penalty

It is permitted to:

- use an open hand to play the ball out of the hand of another player;
- use bent arms to make body contact with an opponent, and to monitor and follow him in this way;
- use one's wheelchair to block the opponent, in a struggle for positions.

It is not permitted to:

- pull or hit the ball out of the hands of the opponent;



- block the opponent with arms, hands, legs, wheelchair or to use any part of the body to displace him or push him away; this includes a dangerous use of the elbow, both as a starting position and in motion;
- hold an opponent (wheelchair, body or uniform), even if he remains free to continue the play;
- endanger an opponent.

**Remarks:**

*Blocking an opponent by holding the wheelchair will be punished progressively.*

*Front contacts are tolerated, but side and rear contacts must be punished. For all these fouls, the chair is considered as part of the player and the non-accidental contact between chairs also constitutes a foul. 7 m shots, free throw, etc. have to be taken from behind the respective lines.*

**Fouls that warrant a personal punishment**

Fouls, where the action is mainly or exclusively aimed at the body of the opponent, must lead to a personal punishment. This means that, in addition to a free throw or 7-metre throw, at least the foul is to be punished progressively, beginning with a warning, then with 2-minute suspensions and disqualification.

**Fouls that warrant an immediate 2-minute suspension**

For certain fouls, the punishment is a direct 2-minute suspension, regardless of whether the player had received a warning earlier.

This applies especially for such fouls where the culpable player disregards the danger to the opponent. Taking into account the decision-making criteria for fouls that warrant a personal punishment, these fouls may include:

- fouls that are committed with high intensity or against an opponent who is “driving” fast;
- holding on to the opponent for a long time, or pulling him down;
- fouls against the head, throat or neck;
- hard hitting against the torso or throwing arm;
- attempting to make the opponent lose body control;
- driving the wheelchair in great speed into an opponent;
- exceeding the maximum classification team points.

**Remarks:**

*In case of a 2-minute suspension / disqualification the maximum classification team points will be reduced by the number of points of the punished player for 2 minutes.*

*Female players: In case no female player is able to play (due to injuries or punishments) the team concerned will be reduced by one player for the rest of the match. In addition the maximum team points will be reduced to 13. A player announced as injured (leading to the reduction of the team size and team points) is not eligible to play in the respective match again (at a later stage).*

#### Fouls that warrant a disqualification

A player who is attacking an opponent in a way that is dangerous to his health is to be disqualified. The special danger to the opponent's health follows from the high intensity of the foul or from the fact that the opponent is completely unprepared for the foul and therefore cannot protect himself.

During the game, in no case is the athlete allowed to rise from the chair (compulsory use of a belt fixing to the chair) to get an advantage. Fixations can only be opened to enable the player to get back into the wheelchair after a fall.

The disqualification of a player or team official is always for the entire remainder of the playing time. For details please refer to the IHF Rules of the Game for Indoor Handball.

The referees shall use the international hand signals.



International  
Handball  
Federation

# **IX. Rules of the Game d) Wheelchair Handball Four-a-Side**

---

*Edition: 19 February 2021*



# Table of contents

<b>Foreword</b>	<b>2</b>
<b>Article 1 – Basics</b>	<b>2</b>
<b>Article 2 – Wheelchair Specifications</b>	<b>6</b>
<b>Article 3 – The Game</b>	<b>7</b>

**Note:** For the sake of simplicity, this rule book generally uses the male form of words with respect to players, officials, referees, and other persons.



## Foreword

The IHF Rules of the Game for Wheelchair Handball Four-a-Side basically follow the IHF Rules of the Game for Wheelchair Handball Six-a-Side, nevertheless with strong influence of beach handball especially concerning the number of players and counting the goals (points). A reduced number of players provides for better individual use of space, increases the dynamics of the game, gives better preconditions for possible separate men's and women's competitions, and creates distinctly better possibilities to recruit players and reduce economic costs.



## Article 1

### 1. Basics

#### 1.1. The Game

Wheelchair handball four-a-side is practised by two teams of four players, including one goalkeeper per team. The aim of each team is to score goals and prevent the other team from scoring. Wheelchair handball shall be based on the spirit of fair play and aimed at physically disabled players.

#### 1.2. The Team

A team delegation consists of a maximum of 14 persons, including a maximum of 10 players and a maximum of four (4) team officials. A minimum of eight (8) players must be present at the beginning of the match.

A maximum of four (4) players per team may be on the court. The remaining players are substitutes. The total number of classification points of players on the court may not exceed a total of 12 points per team at any time in accordance with the classification rules and regulations. For competitions with mixed teams, each team must have at least two female players, unless the rules of the competition concerned state otherwise. At least one female player per team must be on the court at any time.

The goalkeeper is the player designated by the team to defend the goal and plays like the other players sitting in their wheelchair.

Any player present on the court may act as a goalkeeper at any time, but only one player may enter and remain in his own goalkeeper area at the same time. Therefore, the goalkeeper does not wear a special goalkeeper shirt but the same shirt as the rest of the team.

If more than one player enters the goal area at the same time with the intention of defending an opponent or to stop or deflect a ball that goes towards the goal, their team must be penalised with a 7-metre throw.

**Remarks:**

*Teams are not allowed to play with less than four (4) players for tactical reasons in order to use players with higher classification points if there is a possibility to complete the team with players with lower classification points.*

*If any team does so, the referees must order the team's line-up to be corrected and sanction the coach progressively for unsportsmanlike behaviour.*

*If a team suffers several injuries, it may continue the match or the tournament with fewer players.*

*The match may continue, even if one of the teams is reduced to less than four (4) players.*

*If the number of players of a team is reduced, the maximum number of classification points allowed are as follows:*

- *in case of three (3) players on the court, a maximum of 9 points on the court;*
- *in case of two (2) players on the court, a maximum of 6 points on the court;*

*The maximum number of points on the court will always consider the average points per player.*

*It is for the referees to judge whether and when the game should be permanently suspended.*

### **1.3. The Players**

A player must be considered eligible by the Wheelchair Handball Classification Team to play an official competition.

Players in senior competitions must be at least 15 years old to participate (the age on the day of the start of the competition shall be considered). A written parental permission for players aged 15 to 18 must be presented prior to the tournament.

### **1.4. Playing Time**

Matches consist of two sets of ten (10) minutes, which are scored separately.

The half-time break will be five (5) minutes.

Each team has the right to receive a one-minute team time-out in each set of the regular playing time.

The teams must not be granted time-outs in the third set (tiebreaker).

The team requesting a team time-out must be in the possession of the ball.

### **1.5. The Ball**

The balls used for official IHF tournaments shall be in compliance with the provisions of the IHF Ball Regulations, specifically regarding handballs played without resin.

## 1.6. The Court

The provisions for indoor handball and wheelchair handball six-a-side shall apply.

## 1.7. The Goal

The internal dimensions of the goals shall be 3 m x 1.7 m. The catch net in the goals shall be removed (or fixed to the goal net) in order to avoid entangling with the wheelchair.



## 1.8. Scoring and Deciding the Outcome of the Game

A goal is scored when the entire ball has crossed the entire width of the goal line, provided that no violation of the rules has been committed by the shooter or a teammate before or during the shot.

A goal shall be awarded, if there is a violation of the rules by a defender but the ball still goes into the goal.

A goal cannot be awarded, if a referee or the timekeeper has interrupted the match before the ball has completely crossed the goal line.

A goal shall be awarded to the opponents, if a player plays the ball into his own goal, except in the situation where a goalkeeper is executing a goalkeeper throw and the ball does not cross the goal-area line. An own goal scored by any player is awarded with one point.

After a goal is scored, the game is restarted with a goalkeeper throw from the goal area.

If the score is tied at the end of a set, the winner shall be decided by golden goal. The set continues as follows:

- a. After a one-minute break, the set is restarted and continues until one of the teams scores a goal, at which point the set is completed.
- b. If after five (5) minutes neither team has scored a goal, the golden goal is considered completed and the winner of the set is determined through a series of five (5) shoot-outs.

**Comment:** the **shoot-out** consists of a player starting (after the referee's whistle) from the centre of the court with the ball under control (as in a counterattack) who must face the goalkeeper and try to score a goal, complying with the Rules of the Game.

Specifically, in this case, it will not be allowed to place the ball on the lap while pushing the wheelchair for a maximum of 3 seconds.

As in the regular playing time, teams do not have to select one specific goalkeeper but are allowed to

*change goalkeepers during the shoot-out.*

*If the outcome has not been decided after the first round, the shoot-out is continued until one team takes the lead once there has been an equal number of attempts by each team.*

If both sets are won by the same team, this team shall be the overall winner, with a score of 2-0.

If each team wins one set, the result is a tie. In the event of a set tie, the teams will play a third set (tiebreaker) of five (5) minutes. If at the end of the third set the match remains tied, the winner will be determined by a series of five (5) shoot-outs.

If a match is decided by tiebreaker, the overall result shall be 2-1 for the team which has won the tiebreaker.

### **1.9. Spectacular Goals**

Two (2) points are awarded for creative or spectacular goals:

- When a player throws the ball and scores a goal immediately after having made a 360° turn with their wheelchair.

*Note: The turn must be a complete 360° rotation, and the spin may only be done using one hand.*

- When the goalkeeper scores from his goal area.

During the shoot-out, creative or spectacular goals are also awarded two (2) points.

### **1.10. 7-Metre Throw**

If a goal is scored by a 7-metre throw, two (2) points are awarded.

### **1.11. Equipment**

The following material is not permitted:

- Glue for handling the ball
- Protective equipment if including metal components
- Orthoses
- Finger, hand, wrist, etc. braces made of plastic, metal, etc.

It is permitted to use:

- Protective equipment if padded/soft (not including metal)
- Tape for fingers, arms, etc.
- Prostheses

#### **Remarks:**

*The use of prostheses is permitted only with the approval of the Wheelchair Handball Classification Team.*

*The prostheses will only be allowed if covered with padded/soft materials (not including metal).*



*Players who use prostheses to play must use their prostheses during the evaluation by the Wheelchair Handball Classification Team.*

All equipment intended to be used by the teams shall be presented on the occasion of the technical meeting for definite approval.

The IHF Regulations on Protective Equipment and Accessories shall apply.

### **1.12. Playing Kit**

Each team shall have two (2) playing kits (one light colour/one dark colour). The jerseys shall have the players' numbers on the front (10 cm in height).

The players of a same team on the court must wear identical uniforms, including the goalkeeper.

Other sports accessories used, such as wristbands, bandanas, t-shirts worn under the uniform, etc. must be black, white or the predominant colour of the uniform.

Special protective equipment customised to the players does not need to have the same colour as the uniform.

A colour code will be used to identify the class of each player. A sticker with the code and the player's number will be placed on the back rest of the wheelchair after classification.

Class 1 = green	Class 3 = blue
Class 2 = yellow	Class 4 = red

### **1.13. Straps**

Players have to be strapped to the wheelchair at the upper and lower legs in order to avoid lifting or moving/using the legs.

Lifting of court players when playing/defending the ball will be punished with a suspension until the next turnover; lifting of the goalkeeper while defending will be punished with a suspension until the next turnover and the awarding of a 7-metre throw to the opposing team.



## **Article 2**

### **2. Wheelchair Specifications**

The provisions for wheelchair handball six-a-side shall apply.



# Article 3

## 3. The Game

### 3.1. Playing the Ball

The provisions for wheelchair handball six-a-side shall apply.

### 3.2. Violations

Violations shall be handled according to the IHF Rules of the Game for Beach Handball:

- Suspension (reduction until next turnover)
- Disqualification (red card)

It is permitted to:

- use an open hand to play the ball out of the hand of another player;
- use bent arms to make body contact with an opponent, and to monitor and follow him in this way;
- use one's wheelchair to block the opponent in a struggle for positions.

It is not permitted to:

- pull or hit the ball out of the hands of the opponent;
- block the opponent with arms, hands, legs, wheelchair or to use any part of the body to displace him or push him away; this includes a dangerous use of the elbow, both as a starting position and in motion;
- hold an opponent (wheelchair, body, or uniform), even if he remains free to continue the play;
- endanger an opponent.

#### **Remarks:**

*Blocking an opponent by holding the wheelchair will be punished progressively.*

*Front contacts are tolerated, but side and rear contacts must be punished. For all these fouls, the chair is considered as part of the player and a non-accidental contact between chairs also constitutes a foul.*

*7-metre throws, free throw, etc. have to be taken from behind the respective lines.*

#### **Fouls that warrant a personal punishment**

Fouls, where the action is mainly or exclusively aimed at the body of the opponent, must lead to a personal punishment. This means that, in addition to a free throw or 7-metre throw, at least the foul is to be punished progressively, beginning with suspensions and then disqualification.

#### **Fouls that warrant a suspension**

Even a foul with a very small physical impact can be very dangerous and have potentially very serious

consequences, if the timing of the foul is such that the opponent is defenceless and caught unaware. It is the risk to the player and not the seemingly minor nature of the body contact that should be guiding in determining the appropriateness of a disqualification.

This applies especially for such fouls where the culpable player disregards the danger to the opponent. Taking into account the decision-making criteria for fouls that warrant a personal punishment, these fouls may include:

- fouls that are committed with high intensity or against an opponent who is moving fast;
- holding on to the opponent for a long time, or pulling him down;
- fouls against the head, throat or neck;
- hard hitting against the torso or throwing arm;
- attempting to make the opponent lose body control;
- pushing the wheelchair into an opponent with great speed;
- exceeding the maximum classification team points.

#### Fouls that warrant a disqualification

A player who is attacking an opponent in a way that is dangerous to his health is to be disqualified. The special danger to the opponent's health follows from the high intensity of the foul or from the fact that the opponent is completely unprepared for the foul and therefore cannot protect himself.

During the game, in no case is the player allowed to rise from the chair (compulsory use of a belt fixing to the chair) to get an advantage. Fixations can only be opened to enable the player to get back into the wheelchair after a fall.

The disqualification of a player or team official is always for the entire remainder of the playing time.

#### **Remark:**

*In case of a suspension/disqualification the maximum classification team points will be reduced by the number of points of the punished player until the next turnover.*